

SMART LOOP DETECTOR

SLD-12240 SERIES VEHICLE LOOP DETECTOR

USER'S GUIDE



Explain to Model Numbers

SLD - 12240 **A** or **B** **X** or **Y** or **Z**

SLD = Smart Loop Detector
A = Ground PIN: 4
B = Ground PIN: 9

Ground: A (PIN 4)

SLD-12240A-X
SLD-12240A-Y
SLD-12240A-Z



Ground: B (PIN 9)

SLD-12240B-X
SLD-12240B-Y
SLD-12240B-Z

Specifications

Power	12~240 VAC/VDC
Standby current	AC 100 mA Max. DC 80 mA Max.
Detection current	AC 125 mA Max. DC 100 mA Max.
Sensitivity	16 Levels, 0~F
Loop frequency	4 settings (Low, Med-Low, Med-Hi, Hi)
Loop inductance	100~1000 uH
Grounded loop	transformer isolated
Output on time adjustment	1~30 sec., relay A
Output transient adjustment	Presence or pulse on entry, presence or pulse on exit. Relay B
Surge protection	Loop circuitry protected by surge suppressors
Detect output	SPDT relay-Pulse mode → 1A/30VDC SPDT relay-Delay mode → 1A/30VDC
Power indicator	Green LED
Loop fault indicator	Yellow LED
Detect indicator	Red LED
External reset	Low to reset
Operating environment	-4°F ~ 131°F (-20°C ~ 55°C) 0~95% relative humidity
Weight	115 g
Dimensions	91(L) × 42(W) × 79(H) mm

Front panel LED and switch

- (1) POWER: Power Green LED → ON = Power applied to detector.
OFF = No power or fuse is bad.
- (2) DETECT: Detect Red LED → ON = Vehicle being detected.
- (3) LOOP FAULT: Fault Yellow LED → Blinking = Loop Failure.

(The yellow LED is blinking slowly reveals the loop inductance to be too low or the loop to be short and the yellow LED is blinking fast reveals loop inductance to be too high or the loop to be open. If the yellow LED is always on, it means the previous loop fault was detected and it can be reset with the reset button.)

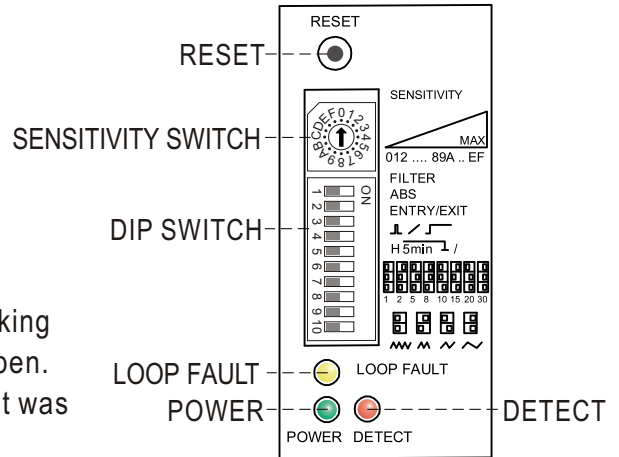

- (4) SENSITIVITY SWITCH : Selections of sensitivity are from 0 to 9 and A to F where 0 stands for the lowest. Sensitive F is the highest sensitive.

SENSITIVITY LEVELS				Unit : $-\Delta L / L \times 100\%$			
LEVEL 0	2.56	LEVEL 4	0.48	LEVEL 8	0.12	LEVEL C	0.03
LEVEL 1	1.28	LEVEL 5	0.32	LEVEL 9	0.08	LEVEL D	0.02
LEVEL 2	0.96	LEVEL 6	0.24	LEVEL A	0.06	LEVEL E	0.015
LEVEL 3	0.64	LEVEL 7	0.16	LEVEL B	0.04	LEVEL F	0.01

- (5) DIP SWITCH :

1. DIP 1 & DIP 2 FUNCTION :

DIP NO.	DIP MODE	FUNCTION
DIP 1	<input type="checkbox"/> ON	2 seconds delay for the relay. It will be no output for a vehicle with a speed that is faster than 8 Km/Hr.
DIP 2	<input type="checkbox"/> ON	Increase detector's sensitivity to avoid the failed detection. Especially in the case of trailer or trucks.

2. DIP 3 & DIP 4 --- OUTPUT B MODE :

DIP NO.	DIP 3	DIP 4	OUTPUT B MODE	DETECT
DIP MODE	OFF <input type="checkbox"/>	OFF <input type="checkbox"/>	Pulse on entry	
	ON <input type="checkbox"/>	OFF <input type="checkbox"/>	Pulse on exit	
	OFF <input type="checkbox"/>	ON <input type="checkbox"/>	Presence mode	
	ON <input type="checkbox"/>	ON <input type="checkbox"/>	Output B will set to the presence mode when the loop failed.	

3. DIP 5 FUNCTION :

DIP NO.	DIP 5	PRESENCE MODE
DIP MODE	ON <input type="checkbox"/>	Continuous detect output is maintained as long as the vehicle remains on the loop.
	OFF <input type="checkbox"/>	Normal mode. Self-tuning to clear false positive. Hold time of 5 minutes for any vehicle detected.

4. DIP 6 & DIP 7 & DIP 8 --- CONTROLS OUTPUT A EXTEND TIME :

DIP NO.	DIP 6	DIP 7	DIP 8	EXTEND	DETECT
DIP MODE	OFF <input type="checkbox"/> <input type="checkbox"/>	OFF <input type="checkbox"/> <input type="checkbox"/>	OFF <input type="checkbox"/> <input type="checkbox"/>	1 sec.	Output A
	<input type="checkbox"/> <input checked="" type="checkbox"/> ON	OFF <input type="checkbox"/> <input type="checkbox"/>	OFF <input type="checkbox"/> <input type="checkbox"/>	2 sec.	Output A
	OFF <input type="checkbox"/> <input type="checkbox"/>	<input type="checkbox"/> <input checked="" type="checkbox"/> ON	OFF <input type="checkbox"/> <input type="checkbox"/>	5 sec.	Output A
	<input type="checkbox"/> <input checked="" type="checkbox"/> ON	<input type="checkbox"/> <input checked="" type="checkbox"/> ON	OFF <input type="checkbox"/> <input type="checkbox"/>	8 sec.	Output A
	OFF <input type="checkbox"/> <input type="checkbox"/>	OFF <input type="checkbox"/> <input type="checkbox"/>	<input type="checkbox"/> <input checked="" type="checkbox"/> ON	10 sec.	Output A
	<input type="checkbox"/> <input checked="" type="checkbox"/> ON	OFF <input type="checkbox"/> <input type="checkbox"/>	<input type="checkbox"/> <input checked="" type="checkbox"/> ON	15 sec.	Output A
	OFF <input type="checkbox"/> <input type="checkbox"/>	<input type="checkbox"/> <input checked="" type="checkbox"/> ON	<input type="checkbox"/> <input checked="" type="checkbox"/> ON	20 sec.	Output A
	<input type="checkbox"/> <input checked="" type="checkbox"/> ON	<input type="checkbox"/> <input checked="" type="checkbox"/> ON	<input type="checkbox"/> <input checked="" type="checkbox"/> ON	30 sec.	Output A

5. DIP 9 & DIP 10 --- FREQUENCY SELECTION : **RESET is needed whenever a frequency is changed.**

DIP NO.	DIP 9	DIP 10	FREQUENCY RANGE
DIP MODE	OFF <input type="checkbox"/> <input type="checkbox"/>	OFF <input type="checkbox"/> <input type="checkbox"/>	High frequency (Hi)
	<input type="checkbox"/> <input checked="" type="checkbox"/> ON	OFF <input type="checkbox"/> <input type="checkbox"/>	Medium-High frequency (Med-Hi)
	OFF <input type="checkbox"/> <input type="checkbox"/>	<input type="checkbox"/> <input checked="" type="checkbox"/> ON	Medium frequency (Med-Low)
	<input type="checkbox"/> <input checked="" type="checkbox"/> ON	<input type="checkbox"/> <input checked="" type="checkbox"/> ON	Low frequency. (Low)

When more than two loops are used, please set up different frequencies in order to eliminate the crosstalk.

(6) RESET Button : RESET button can reset the detector.

(7) Typical saw cut loop installation :

PERIMETER (M)	NUMBER OF TURNS	PERIMETER (M)	NUMBER OF TURNS
3~4M	6	4~6M	5
6~10M	4	10~20M	3
20~UP	2		

(8) Teflon loop is recommended and the maximum length could 150 meter.

(9) The loop should be installed in an area where has no electric reach overhead door near by.

(10) Loop Failure Memory:

The detector can indicate a prior loop failure even if the failure.

This is displayed on the yellow LED (steady on). Any reset will memory failure.

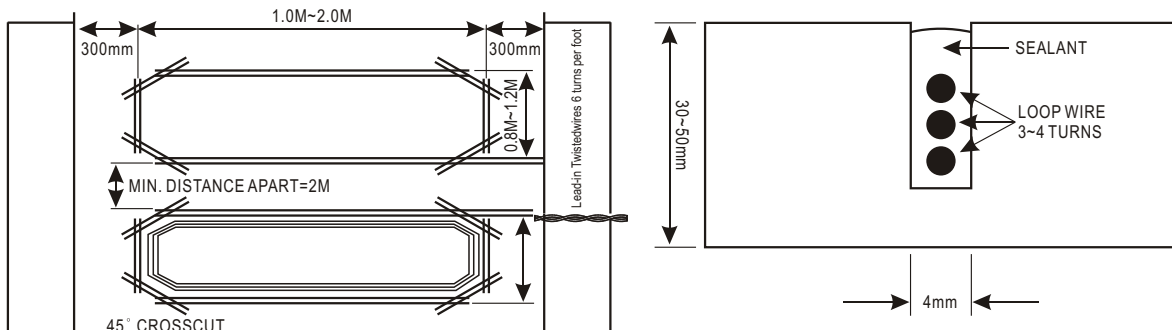

(11) Troubleshooting:

- check POWER LED (Green) : if LED is off , check input power
- Press RESET button
- If LOOP Fault LED (Yellow) is blinking:
 - blinking slowly : Loop inductance to be too low or loop wire number of turns is lower than required or loop to be short.
 - blinking fast: Loop inductance to be high or loop wire number of turns is higher than required or loop to be open.
- When loop wire number of turns is lower than required(frequency too high): Try DIP 9 and DIP 10 switch to “ON” , if loop fault indicator still blinking, increase number of loop is needed.
- When loop wire number of turns is higher than required(frequency too low): Try DIP 9 and DIP 10 switch to “OFF” , if loop fault indicator still blinking, decrease number of loop is needed.

Type of wiring Connection Output

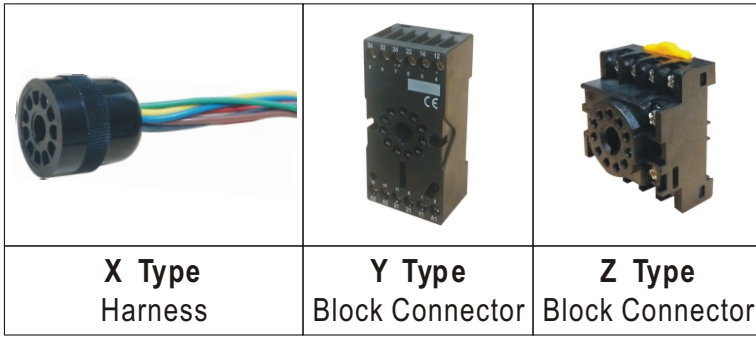

X Type
Harness

Y Type
Block Connector

Z Type
Block Connector

Above picture is not included, nevertheless it is also available in place of the terminal block.

(X Type) Wiring Harness Connections:

ITEM	COLOR	PIN No.	Connection Notes (SLD-12240A)	Connection Notes (SLD-12240B)
WIRE 1	White	PIN 1	Power, non-polarity	Power, non-polarity
WIRE 2	Black	PIN 2	Power, non-polarity	Power, non-polarity
WIRE 3	Orange	PIN 3	Relay B (N.O.)	Relay B (N.O.)
WIRE 4	Green	PIN 4	Ground	Relay B (COM)
WIRE 5	Yellow	PIN 5	Relay A (COM)	Relay A (COM)
WIRE 6	Blue	PIN 6	Relay A (N.O.)	Relay A (N.O.)
WIRE 7	Gray	PIN 7	Loop	Loop
WIRE 8	Brown	PIN 8	Loop	Loop
WIRE 9	Red	PIN 9	Relay B (COM)	Ground
WIRE 10	Pink	PIN 10	Relay A (N.C.)	Relay A (N.C.)
WIRE 11	Violet(Purple)	PIN 11	Relay B (N.C.)	Relay B (N.C.)

PIN Connections

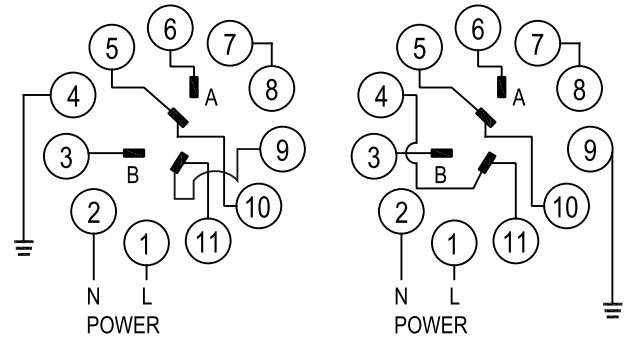

SLD-12240A

Ground: A (PIN 4)

SLD-12240B

Ground: B (PIN 9)

Quick Terminal Block and Connections

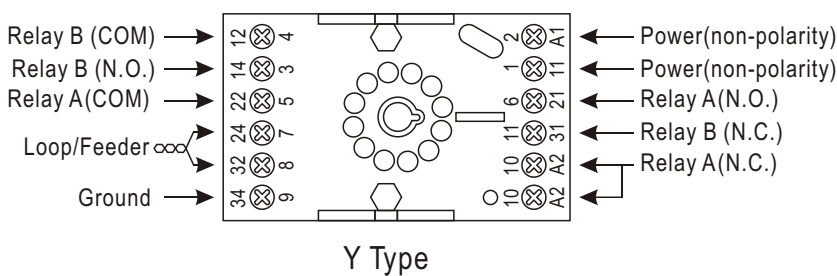

Y Type

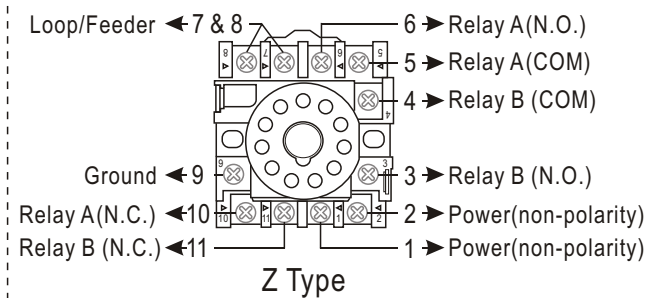

Z Type

Schematic diagrams

(unit: mm)

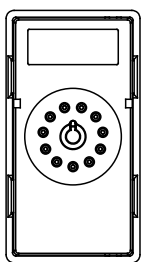

Back View

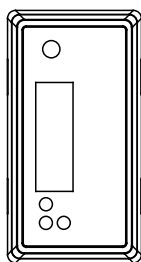

Front View

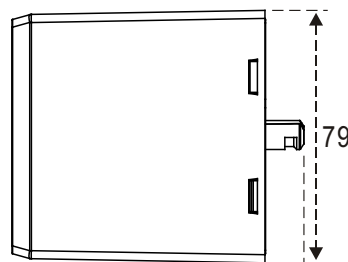

Side View

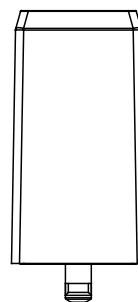

Upper View

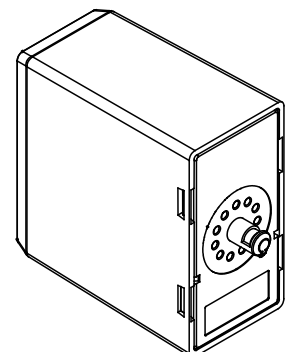

3D Side View